

(1) Suppose for monochromatic light, the index of refraction of this a slab is  $n$  and the glass slab has a thickness  $t$ . Find the displacement  $d$  of the light after it passes through the slab from the undeviated path of the light. Assume the cube is surrounded by air.

(2) A coin is on the bottom of a pool of a depth of 1 m. What is the depth of the coin as seen from outside the pool? For air,  $n=1$  while for water,  $n=1.333$ .

(3) A light submerged in water sends a beam of light towards the surface at an angle of incidence of  $37^\circ$ . What is the angle of refraction in air? For air,  $n=1$  while for water,  $n=1.333$ .

(4) The wavelength of a red helium-neon laser light in air is 632.8 nm. (a) What is its frequency? (b) What is its wavelength in glass of index of refraction 1.5? (c) What is its speed in glass?

(5) Show that for a retroreflector the light emerges along a path parallel to the incident path.

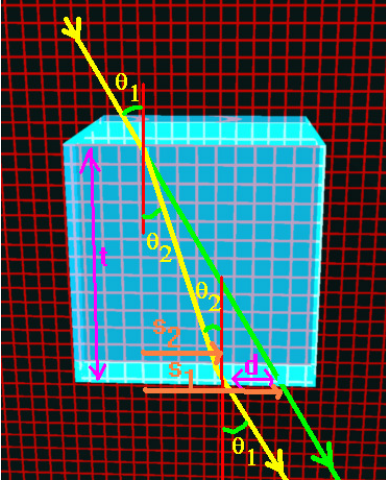

(1) Suppose for monochromatic light, the index of refraction of this glass slab is  $n$  and the glass slab has a thickness  $t$ . Find the displacement  $d$  of the light after it passes through the slab from the undeviated path of the light. Assume the cube is surrounded by air.

Solution: the ray is refracted at an angle  $\theta_2$  which is determined from Snell's law. In the image shown, light does not actually follow along the green path rather this represents the undeviated light path.

The normal to the actual emergent path of the light is separated from the incident normal by a distance equal to  $s_2 = t \tan(\theta_2) \approx t \sin(\theta_2)$ .

The normal to the emergent undeviated path of the light is separated from the incident normal by a distance of

$$s_1 = t \tan(\theta_1) \approx t \sin(\theta_1)$$

As I have shown it here, we are assuming a monochromatic light entering the slab and the angles involved here are small enough so that the *sin and tangent are almost interchangeable*.

The difference between  $s_1$  and  $s_2$  then gives us the deviation of the light path:

$$d = t [\sin(\theta_1) - \sin(\theta_2)]$$

For this particular wavelength of light, we have from Snell's law:

$$\sin(\theta_2) = \frac{n_1}{n_2} \sin(\theta_1)$$

This means that we can express the deviation as:

$$d = t \sin(\theta_1) \left(1 - \frac{n_1}{n_2}\right)$$

If monochromatic light is not shining on the cube in the first place, we will see a dispersion in the colors of light coming from the cube. How? Let's first assume the system is surrounded by air so that  $n_1=1$ . We'll call the index of refraction simply  $n$  inside the glass. Then, in a simpler form, we have:

$$d = t \sin(\theta_1) \left(1 - \frac{1}{n}\right)$$

Now let's let the incoming light be composed of a purple ray and a red ray. Let the respective indices of refraction for these two rays be

$$n_{\text{red}} \text{ and } n_{\text{purple}} \text{ with } n_{\text{red}} < n_{\text{purple}}$$

The light will disperse with a separation between the two rays given by:

$$d_{\text{red}} - d_{\text{purple}} = t \sin(\theta_1) \left(1 - \frac{1}{n_{\text{red}}} - 1 + \frac{1}{n_{\text{purple}}}\right) = t \sin(\theta_1) \left(\frac{1}{n_{\text{purple}}} - \frac{1}{n_{\text{red}}}\right)$$

[Here is a java applet to show parts of this.](#)

(2) A coin is on the bottom of a pool of a depth of 1 m. What is the depth of the coin as seen from outside the pool? For air,  $n=1$  while for water,  $n=1.333$ .

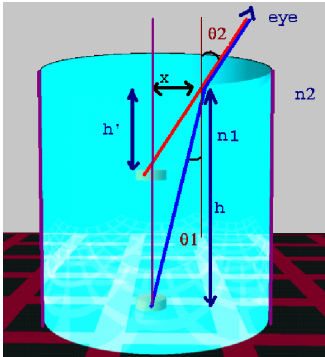

Seen from above the water surface, the coin appears to be at the intersection of the ray entering the eye and the vertical passing through the coin. Applying Snell's law to the water-air surface gives,

$$n_1 \sin(\theta_1) = n_2 \sin(\theta_2).$$

For small angles, the sin and tan are almost equal, and  $\tan(\theta_1)=x/h$  and  $\tan(\theta_2)=x/h'$ . If we use this in Snell's law, we then have

$$n_1 \frac{x}{h} = n_2 \frac{x}{h'}$$

We can solve this for  $h'$ :  $h' = h \left[ \frac{n_2}{n_1} \right]$ . Water has an index of refraction of 1.333 so  $h' = 1(1/1.333) = .75\text{m}$ .

One of the consequences of refraction is the fact that a body immersed in a transparent medium appears nearer to the observer than it actually is. This is probably most dramatically demonstrated by looking at a floating thermometer while sitting in a swimming pool: the length of the thermometer will look much shorter when viewed from an angle.

(3) A light submerged in water sends a beam of light towards the surface at an angle of incidence of  $37^\circ$ . What is the angle of refraction in air? For air,  $n=1$  while for water,  $n=1.333$ .

Solution: Snell's law says:

$$n_1 \sin(\theta_1) = n_2 \sin(\theta_2) \Rightarrow \sin(\theta_2) = \frac{n_1}{n_2} \sin(\theta_1) \Rightarrow \theta_2 = \sin^{-1} \left( \frac{n_1}{n_2} \sin(\theta_1) \right)$$

$$\text{Here, } n_2=1 \text{ and } n_1=1.333. \text{ Thus: } \theta_2 = \sin^{-1} \left( \frac{1.333}{1} \sin(37) \right) = 53.3^\circ$$

(4) The wavelength of a red helium-neon laser light in air is 632.8 nm. (a) What is its frequency? (b) What is its wavelength in glass of index of refraction 1.5? (c) What is its speed in glass?

Solution: (a) The wavelength, frequency and speed are related by  $c = f\lambda$ . Here,  $\lambda = 632.8 \times 10^{-9} \text{ m}$  and in air,  $c = 3 \times 10^8 \text{ m/s}$ . Thus,  $f = 4.74 \times 10^{14} \text{ Hz}$ . (b) The speed of light is related to the index of refraction by  $n = c/v$ . Thus,  $v = c/n = 2 \times 10^8 \text{ m/s}$ . This then gives the wavelength in glass as  $\lambda = v/f = 423 \text{ nm}$ . (c) The answer is  $2 \times 10^8 \text{ m/s}$ .

(5) Show that for a retroreflector the light emerges along a path parallel to the incident path.

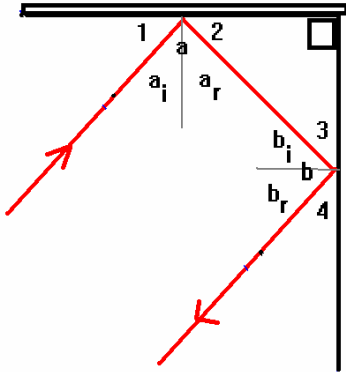

Solution: Consider the retroreflector construction shown. It consists of two mirrors placed at 90 degrees to each other.

Firstly, the law of reflection says that the angle of incidence is equal to the angle of reflection. This means that angle 1 is the same as angle 2 (although note that angle 1 is not the angle of incidence and angle 2 is not the angle of reflection). I ought to thus show that angle 1 is the same as angle 2.

$$\angle 1 = 90 - \angle a_i \text{ and } \angle 2 = 90 - \angle a_r \text{ but } \angle a_i = \angle a_r \Rightarrow \angle 2 = 90 - \angle a_i = \angle 1$$

$$\therefore \angle 1 = \angle 2$$

We can also use the same argument to show  $\angle 3 = \angle 4$ .

There is a connection between (angle 1, angle 2, angle a) and (angle 3, angle 4, angle b):

$$\angle 1 + \angle 2 + \angle a = 180 \Rightarrow \angle a = 180 - \angle 1 - \angle 2$$

$$\angle 3 + \angle 4 + \angle b = 180 \Rightarrow \angle b = 180 - \angle 3 - \angle 4$$

We also have a connection between angles 2 and 3:  $\angle 2 + \angle 3 = 90$

Add angles a and b:

$$(\angle a) + (\angle b) = 360 - [\angle 2 + \angle 3] - [\angle 1 + \angle 4] = 360 - 2[90] = 180$$

**Thus the reflected ray is parallel to the incident ray for a retroreflector.**