

(1) Time dependence of a RL circuit. You know that Faraday's law says  $\text{emf} = -L \frac{dI}{dt}$ . Suppose you have a series RL circuit as shown. At  $t=0$ , leave  $s_2$  open but close  $s_1$ . The question is how does the current through the circuit behave with time?

Solution: **The current begins to initially flow through the circuit. From Faraday's law and Lenz's Law, due to the fact that a time rate of change of the current induces an emf which will tend to oppose the change, we will have a "back"**

**emf which tends to oppose the emf from the battery.** This emf is given by

$$V_L = -L \frac{dI}{dt}$$

Now apply Kirchoff's law: we get

$$V - IR + V_L = 0.$$

Remember the emf produced by the changing current through the inductor is in the opposite sense, **hence the + sign**. So we then have

$$V - IR - L \frac{dI}{dt} = 0$$

Let  $x \equiv \frac{V}{R} - I$ . Then, we can write

$$x + \frac{L}{R} \frac{dx}{dt} = 0.$$

If we let  $\tau = L/R$ , then this is even simpler:

$$x + \tau \frac{dx}{dt} = 0.$$

This equation can be rearranged to appear in a more familiar form:

$$\frac{dx}{x} = -\frac{dt}{\tau} \Rightarrow \ln\left(\frac{x}{x_0}\right) = -\frac{t}{\tau}$$

so long as you start time at  $t=0$ . You know what the solution to this is, namely a natural logarithm. Thus,

$$\ln\left(\frac{x}{x_0}\right) = -\frac{t}{\tau}.$$

We can exponentiate this to give  $x = x_0 e^{-t/\tau}$ . If we now replace  $x$ , we find that the **current as a function of time is given by**

$$I(t) = \frac{V}{R} (1 - e^{-t/\tau})$$

where  $\tau = L/R$ . and  $V$  is the emf from the battery.

Note that the maximum value of the current occurs at an infinite time and is given by Ohm's law:  $I = \frac{\epsilon}{R}$  where the emf is that produced by the battery.

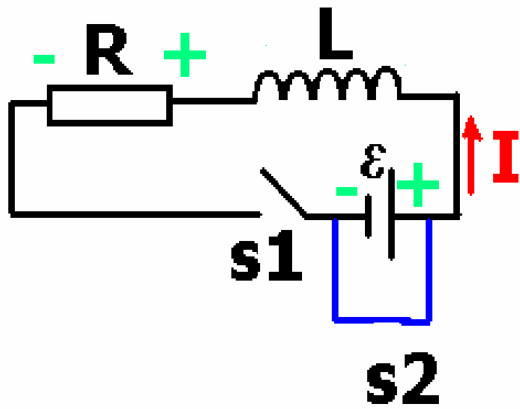

(2) Suppose that at some long time after  $s1$  is closed, you obtain the theoretical maximum current through the circuit  $I = \frac{\epsilon}{R}$ . Now, leaving  $s1$  closed, close switch  $s2$ . Describe the time dependence of the current through the circuit.

Solution: Application of Faraday's and Lenz's laws would say something like this: changes in the stored magnetic energy in the inductor will provide a source of emf. We've immediately switched off the source of current to the inductor. That means that the flux is going to be changing in the inductor. According to Lenz's law, the inductor is going to do everything possible to keep this from happening (but, for normal (pun here!) circuit elements, of course, our poor inductor is fighting a lost cause). **Thus, the inductor will induce an emf which will result in a current which is in the same direction as the current was right before it was shut off by switch  $S2$ .** (These words were chosen very carefully). That means that we have by a straight-forward brute force application of Kirchoff's laws:

$$V_L - IR = 0$$

Although many texts say this differently, I contend that this is the way it ought to look. However, note that the + and - notations in the picture above might need to be changed since there is no longer a battery to reference the positive and negative ends of the inductor. In any event, from Faraday's law, we then have (walk in the direction of  $I$  across the inductor and the resistor):

$$V_L = -L \frac{dI}{dt}$$

$$-L \frac{dI}{dt} - IR = 0$$

We can make this simpler in appearance to what we had before:

$$L \frac{dI}{dt} + IR = 0$$

Now, as before let  $\tau = L/R$  and rearrange to give

$$\frac{dI}{dt} = -\frac{I}{\tau}$$

This can be rearranged to give a more familiar form:

$$\frac{dI}{I} = -\frac{dt}{\tau} \Rightarrow \ln\left(\frac{I}{I_0}\right) = -\frac{t}{\tau}$$

If you assume that you close  $s2$  at  $t=0$ , then this appears as  $\frac{dI}{I} = -\frac{1}{\tau}$ . You recognize that this is a logarithmic form:  $\ln\left(\frac{I}{I_0}\right) = -\frac{t}{\tau}$ . If you exponentiate this, then the result is

$$I = I_0 e^{-\frac{t}{\tau}}$$

$$\text{If } I_0 = \frac{\epsilon}{R}, \text{ then } I = \frac{\epsilon}{R} e^{-\frac{t}{\tau}}$$

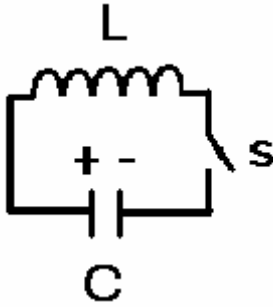

(3) Consider the circuit shown. Initially the capacitor has a charge  $Q$ . At  $t=0$ , the switch  $s$  is closed. Describe the time dependence of the circuit.

Solution:

The conventional current will act in such a way that charges are taken from the positive plate, moved through the inductor, and placed on the negative plate. According to this, then we have that the capacitor is acting as if it were a source of emf. I want to do this problem with out ever crossing the capacitor.

Application of Kirchoff's laws then gives:

$$V_c - V_L = 0$$

or, more clearly, we have:

$$\frac{Q}{C} + L \frac{dI}{dt} = 0 \Rightarrow \frac{d^2I}{dt^2} + \frac{1}{LC} I = 0$$

Non-calculus students will need to remember that this gives the solutions for  $I$ :

$$I(t) = I_m \sin(\omega t + \phi)$$

where

$$\omega = \frac{1}{\sqrt{LC}}$$

The charge difference across the capacitor is given by:

$$I = \frac{dQ}{dt} \Rightarrow Q(t) = \int I_m \sin(\omega t + \phi) dt = -\frac{I_m \cos(\omega t + \phi)}{\omega}$$

At  $t=0$ , we have then

$$Q(0) = Q_0 = -\frac{I_m}{\omega} \Rightarrow I_m = -\omega Q_0$$

This suggest for this problem, if we would write:

$$Q(t) = Q_0 \cos(\omega t + \phi)$$

Then

$$I = \frac{dQ}{dt} = -\omega Q_0 \sin(\omega t + \phi) \text{ with } I_m = \omega Q_0$$

and, we can find the potential across the inductor as:

$$V = -L \frac{dI}{dt} = \omega L Q_0 \cos(\omega t + \phi)$$

Energy sloshes between an electrostatic energy and a magnetostatic energy. How this happens is this:

At any time, the energies are:

$$U_m = \frac{1}{2} L I^2 = \frac{L I_m^2}{2} \sin^2(\omega t + \phi)$$

$$U_E = \frac{Q^2}{2C} = \frac{Q_0^2}{2C} \cos^2(\omega t + \phi)$$

It's possible though to eliminate  $L$  from the discussion by:

$$L = \frac{1}{\omega^2 C}$$

$$\text{This then gives: } U_m = \frac{1}{2} L \omega^2 Q_0^2 \sin^2(\omega t + \phi) = \frac{1}{2} \frac{Q_0^2}{C} \sin^2(\omega t + \phi)$$

Ok, now add the two to obtain the total energy which is constant in time:

$$U = U_E + U_M = \frac{Q_0^2}{2C}$$

This is a "tank" circuit, the resonance of which provides the basic circuit for radio tuners.

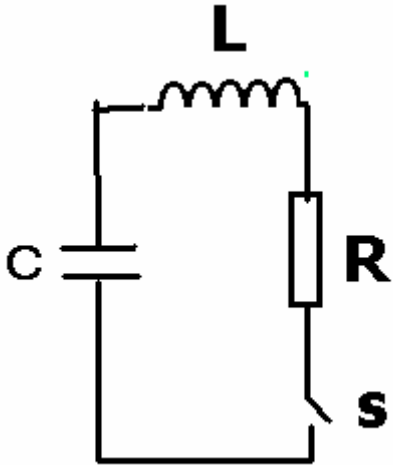

(4) The RLC circuit. Suppose that at  $t=0$ , the capacitor has a total charge  $Q_0$ . Then, the switch is closed. Describe the subsequent behavior of the circuit.

Students will need to remember that if  $R$  is fairly small, then the charge across the capacitor as a function of time is given by

$$Q = Q_0 e^{-\frac{Rt}{2L}} \cos(\omega_d t)$$

where

$$\omega_d = \sqrt{\frac{1}{LC} - \left(\frac{R}{2L}\right)^2}$$

This is easy enough to obtain from Kirchoff's laws but it is now time to move on.